

Quality Since 1974



EXCEEDING YOUR EXPECTATIONS THROUGH SUPERIOR WORKMANSHIP AND DESIGN



Quality Time...

Quality Workmanship & Design.

Pier Pleasure invites you to take a look at our quality workmanship and design. Pier Pleasure goes the extra mile to meet or exceed your expectations. Extra effort is given to remove defects, sharp edges and corners. This ensures safety, maintains quality standards and assures your satisfaction. Pier Pleasure's standards for excellence demand high-quality components, such as non-corrosive stainless steel bolts, stainless cables, brass nuts, aluminum pulleys with brass sheaves and aluminum construction.

But it takes more than quality components to produce a quality product, it takes a team of dependable, dedicated people, all working together to make Pier Pleasure products and services what they are. We continually strive to exceed

our customer's expectations and to ensure the customer's satisfaction with the product's performance. Without quality people, our products would just be another group of mediocre products found in today's marine market.

We believe the true value of a product can only be determined by the manufacturer's confidence in the product and when the customer's expectations of the product are satisfied by its performance.

Pier Pleasure will never sacrifice quality, performance, durability or customer satisfaction, just to reduce the cost. After all, Pier Pleasure's name and reputation are on the line. We appreciate your consideration of Pier Pleasure for your lift and dock needs!



Vinyl Surface

Clay
Woodgrain



Tan
Woodgrain

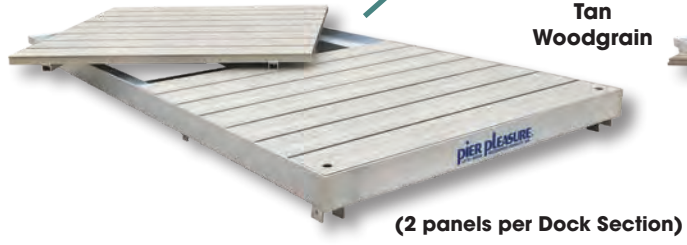

(2 panels per Dock Section)

Gray

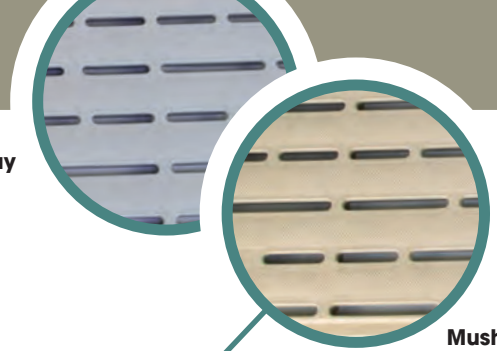

Mushroom

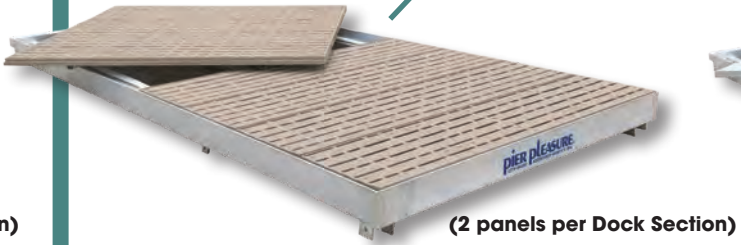

(2 panels per Dock Section)

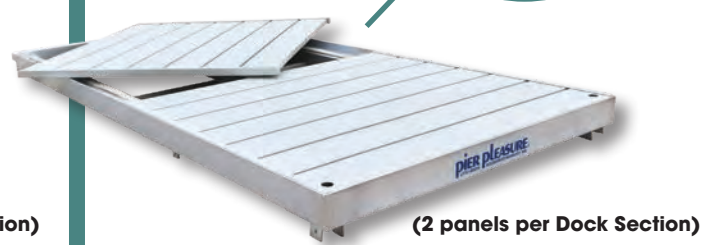

(2 panels per Dock Section)

Vinyl Surface



Wood absorbs heat, but Brock Deck planks reflect the sun's rays. Stays cool to the touch.



The Brock Deck provides excellent resistance to stains and is easy to clean. Available in tan or clay.



Grooved design pattern provides a very stylish appearance, an excellent walking surface for shoes or bare feet and quick water drainage. It is slip resistant. Unlike treated wood, there are no toxic chemicals in Brock's decking, so it's safe for your family and pets. And it's 100% recyclable.

Titan

Titan Deck was engineered so your dock will be the last thing on your mind. We know you would rather be having fun with your dock than working on your dock.

Titan Deck is made out of polypropylene, a sturdy plastic, that will take everything you and Mother Nature can throw at it. It comes standard with aluminum stiffeners for extra reinforcement.

All Titan Deck products come with UV protection which will prevent significant fading. Titan Deck will also handle any wild weather changes.



Aluminum Surface

Extruded aluminum deck planks are painted with a baked-on enamel finish that has a light gray textured surface. The grooved design is attractive and assists with quick water drainage. The aluminum deck panels are durable and will last for many years.





Cedar Surface

Western Red cedar is used to maintain the quality and durability that customers have come to expect from Pier Pleasure. 5/4" x 6" planks are used to construct the removable panels. Enjoy the natural look of wood while having all the advantages of maintenance free aluminum construction and Pier Pleasure features.



Features and Benefits

Pier Pleasure's dock system offers many features and benefits not found in any other dock system. These unique features make them simple to install, level and remove.

Each dock section is designed to hold 60 lbs. of water in its 100% welded frame (Photo A).

This feature adds stability during normal use and helps to hold the dock system in place during storms, high winds and wave action. Water is drained by removing the plugs under each section before removal in the fall. This is a great feature!

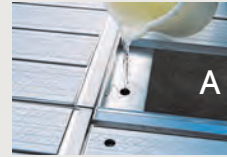

Available 4'x8', 5'x8' and 6'x8' sections are connected end to end and side to side by Pier Pleasure's unique interlocking hinge. The first sections can form a ramp up or down allowing the dock system to adapt to any shoreline.

Pier Pleasure's dock legs are braced from side to side and front to back for maximum stability (Photo B). There are no leg posts above the dock surface and legs do not need to be removed, which makes installation, removal and storage easier. This also maintains a clean appearance.



Pier Pleasure's adjustable legs allow leveling from the top of the dock without entering the water (Photo C). Each leg levels independently and there are no set screws or holes to line up (Photo D). The leg



adjustment mechanism has 18" of adjustment and carries a full lifetime warranty.

Height indicators on each leg make leveling easy and accurate. The indicators show you the distance from the top of the dock to the water. All bolts, pins and fasteners in the dock system are stainless steel which means no corrosion, no maintenance and long-term clean appearance.

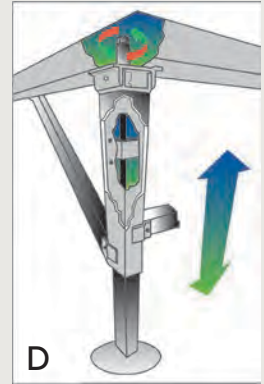

Pier Pleasure's design flexibility allows unlimited layout options. Additional sections can easily be added later in any location to modify your layout as your needs change.

Pier Pleasure provides buyers the flexibility to design a layout that best fits their needs. An unlimited number of layouts can be created to meet any taste or desire. Design a slip for your boats or a large platform with plenty of room to share fun times with your family and friends. Whatever the case, get off the deck and make memories on your dock.



Popular Dock Formations

Layouts shown with 4' x 8' dock sections and optional corner sections.

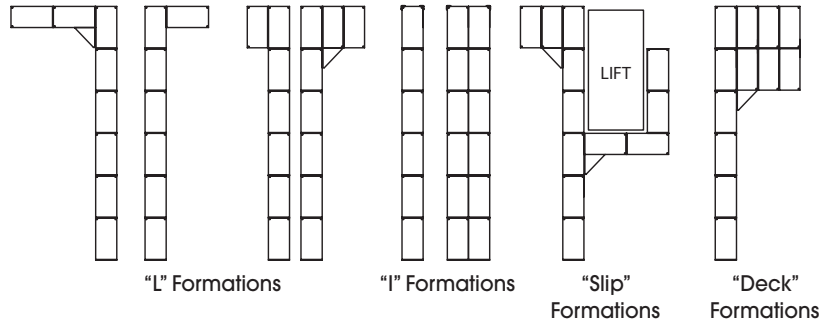

Unique Dock Formations

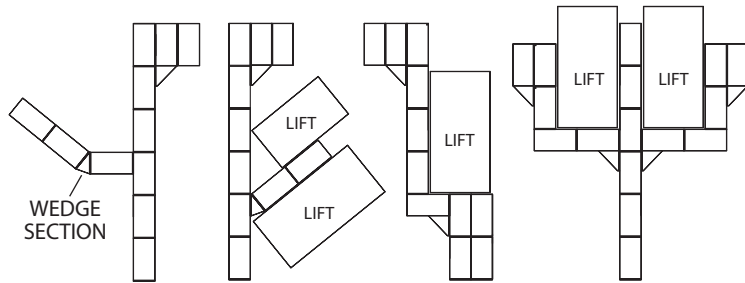

Ideal For Limited Storage Space

Having limited space for storage can complicate storing sections. The sectional design of the Pier Pleasure system allows you to stack the frames and panels where there is limited space.



Wedge Section

The wedge section allows you to create a simple slip for boat lifts when there is limited space.



Large Platform

Pier Pleasure's dock sections can be easily configured to create a large platform. This will give you ample space for everyone to enjoy the dock without feeling crowded.

Note: Large platforms may not meet local and state regulations in your area.



DOCK INSTALLATION

~ Installed & Removed



Carry the dock frame out onto the dock. 4' x 8' section frames with legs weigh 65 lbs.



Connect dock sections using Pier Pleasure's unique, interlocking hinges



Lower the section into the water with the use of a rope. No bolts, pins or tools are needed to connect dock sections.

SECTIONAL DOCK SYSTEM



Step Section

The step section is an alternative choice to easily transition down to the desired height needed to start your dock.



Listening To Customers

Listening to your requests and designing a dock that meets your requirements is what Pier Pleasure is all about. The Pier Pleasure dock system allows you to design a dock that will succeed with any shoreline or dock layout you may require. If you have a distinctive layout or design request, Pier Pleasure will be pleased to assist you with your dock planning. Even if you want to purchase a simple straight out dock, you will feel like you purchased something exceptional.



Dock Ramped Down

Placing dock sections on a shoreline with rocks and natural riprap can be challenging. Pier Pleasure's dock hinges allow for the flexibility to form a ramp over any obstacles on your shoreline.



Dock Ramped Up

Pier Pleasure's hinge system allows you to form a ramp with your first dock section.

Without Entering The Water ~ Can Be Installed & Removed By One Person



Install panels into the dock frame.



Level section with the use of the adjustment crank. Level indicators on the side of each leg show you when you have reached your desired height.



Add water to the tubular frame for additional weight and stability.



Install dock accessories wherever you choose. Spaces between deck planks allow you to install accessories without the need to drill unsightly holes.

DOCK REMOVAL



After the accessories are removed and water is drained, remove dock frames with the optional tripod winch. Carry frames and stack on shore for storage.



Vinyl Bench

Enjoy the day on a maintenance-free vinyl bench. The aluminum frame with slanted backrest and secured vinyl planks provides a comfortable place to relax and enjoy your dock. Available in tan or gray vinyl.

Bench Arm Rests - Add bench arm rests to hold your drink while enjoying your warm afternoon. Available in tan or gray vinyl.

Bench Canopy - Want to get out of the sun? Relax in the shade. Frame folds down for easy storage. Cover is available in all canopy fabrics and colors on page 29.



(2) 4' Benches



Aluminum Dock Stairs

Safe access in and out of the water for young children and older adults. Adjustable for your lake bottom with drop legs that can be easily leveled. Available in 5, 6, 7 and 8 steps.



Ladder

The all-aluminum ladder extends high above the dock for enhanced leverage when climbing out of the water. Available in 3-step or 4-step.



Tripod Winch

The tripod winch allows you to remove the sections easily without having to get in the cold water letting you extend the use of your dock well into the fall.



Pipe Brackets

Pipe Brackets can be added anywhere on the dock to install pipe into the lake bottom. Available for 1 1/4" I.D. pipe or 1 1/2" I.D. pipe.



Horizontal Bumpers

Protect the exterior of your boat. Can be moved as needed.



Vertical Bumpers

Protect your boat. The vertical bumpers are sturdy, hold the boat away from the dock and are easy to tie to. Available in 2-foot and 4-foot lengths. The poly bumper is secured to the aluminum post with stainless steel bolts.



Wheel Cart

Simplify installation and removal of your dock with the use of a wheel cart. A great tool for moving sections to and from the storage location.



Canoe Rack

The canoe rack makes storage of your canoe or kayak simple. The canoe is at the water – ready to go when you are. (Additional supports are available for heavier equipment)



Starter Hinge

Safely remove gaps by attaching Pier Pleasure dock sections to stairways, retaining walls and other dock systems.



Corner Protector

Protect the exterior of your boat by placing a vinyl corner protector on each exposed dock corner.



Flagpole & Mounting Bracket

Display your colors proudly. This telescoping flagpole expands to 20 feet in height. The mounting bracket makes it easy to place the flagpole wherever you want.



Dock Furniture

This 3-piece set includes two fabric swivel chairs. The 24" diameter table is powder-coated and comes with an umbrella hole. Chair weight capacity is 250 pounds each. Chair style subject to change. Umbrella not provided.



Split Footpad

There is a solution for dock installations with a mucky lake bottom. Split footpads allow you to install the dock easily in the spring and break the suction upon removal in the fall.



Dock Leg Extensions

As your needs change in the future, dock leg extensions can be added to any leg where more height is needed. Available in 6", 12", 18" and 24" lengths.



See www.pierpleasure.com for new and additional dock accessories.



Double Kayak Rack

Store your kayaks or canoes on the side of your dock with the Double Kayak Rack. This 2-piece rack fastens to the outside of your dock. Save space and time. Optional eye bolts may be installed to the provided holes to tie down your equipment with bungee cords.



Movable Cleats

Place these aluminum cleats where needed. Available with 6" or 10" cleat.



Pole Bracket

Easily store objects like a fish net inside the pole bracket. Inside diameter 1-1/2" and can be installed anywhere you choose on the dock. Fish net not included.



Fishing Rod Holder

Organize your fishing equipment out on the dock with this one-piece rack and drink holder. Holds 2 rods and has openings for 2 drinks.



Solar Lights

Illuminate your dock at nightfall for additional safety. Brackets are available in flush mount, 6", 12" and 18" height. Use the bracket and lite combination to place anywhere on your dock.





Enjoyable Experiences...



Elevated Standards

Pier Pleasure continually strives to elevate the standards of existing and new product designs. The construction of all product lines using non-corrosive fasteners, custom aluminum shapes and other high-quality components support Pier Pleasure's commitment to exceeding the customer's expectations.

Taking customer's valuable comments and using that input to always improve is a priority at Pier Pleasure. Satisfied customers are a result of maintaining elevated standards. Extra effort is given to remove sharp edges, corners and other defects. This ensures safety, maintains elevated standards and ensures your satisfaction.



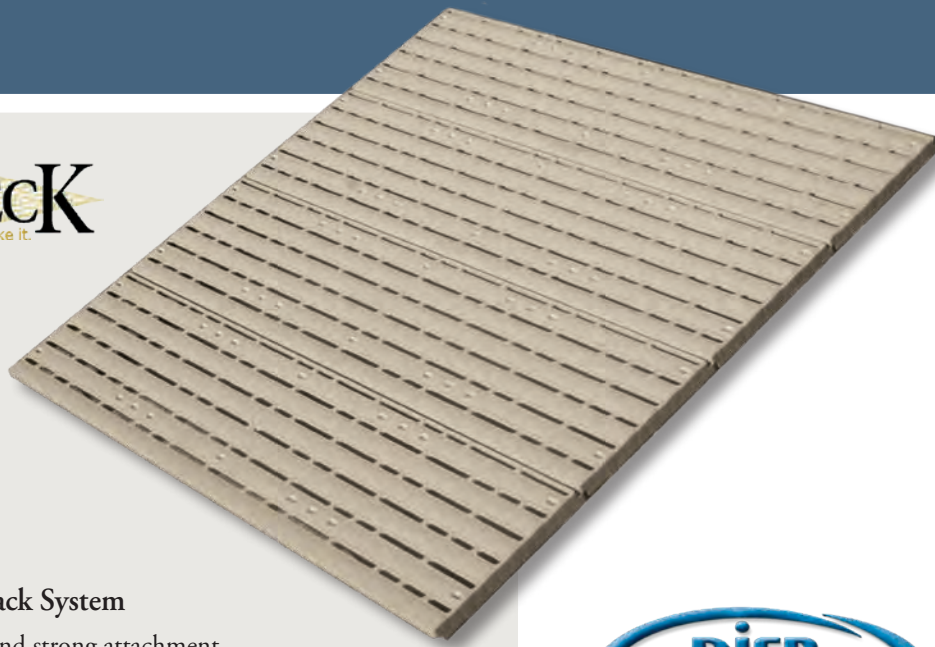

Features and Benefits

Adaptable Inside Track System

- Allows for simple and strong attachment of dock legs and braces.
- Set screw posts can be added in any location for additional support.
- Dock accessories can easily be positioned where you choose.

Removable Deck Panels

- Makes roll-in sections lighter for installation and removal.
- Easier to repair if damage occurs.

Top Rail is 3 5/8" Tall

- Protects the ends of the deck panels from damage.
- Provides strong structural design for rigorous daily use.
- Allows Pier Pleasure's Sectional Dock accessories to be attached to the roll-in frame.

Stainless Steel and Brass Fasteners

- No corroded fasteners when trying to make adjustments.
- Maintains a clean appearance.

Lifetime Leg Screw Warranty

- The nut for the leg screw is made from maintenance-free polyethylene (UHMW).
- All fasteners used in the dock leg are stainless steel and brass.

Titan Surface Panels

Titan Deck was engineered so your dock will be the last thing on your mind. We know you would rather be having fun with your dock than working on your dock.

Titan Deck is made out of polypropylene, a sturdy plastic, that will take everything you and Mother Nature can throw at it. It comes standard with aluminum stiffeners for extra reinforcement.

All Titan Deck products come with UV protection which will prevent significant fading. Titan Deck will also handle any wild weather changes and is backed with a 12 year limited warranty.

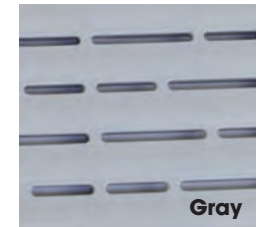

Truss-Style Dock

- Gives you the highest strength and lightest weight available.
- Open design allows large waves to flow through the dock section rather than pounding against it.
- The ends of each deck panel are covered by the top rail for a clean appearance and protection against wear.

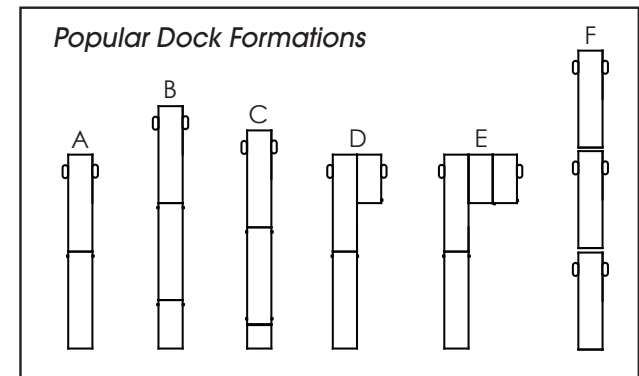
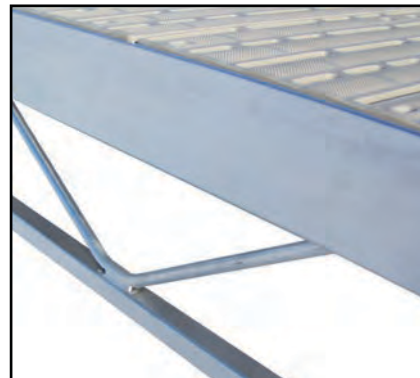

Design Flexibility to Meet Your Needs

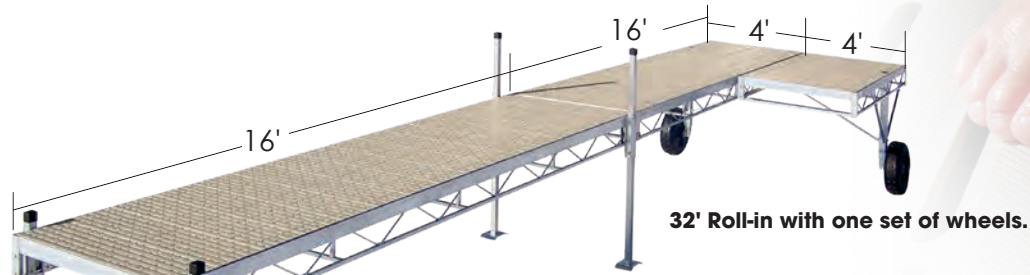

32' Roll-in with one set of wheels.



Truss-style dock section with set screw post legs.

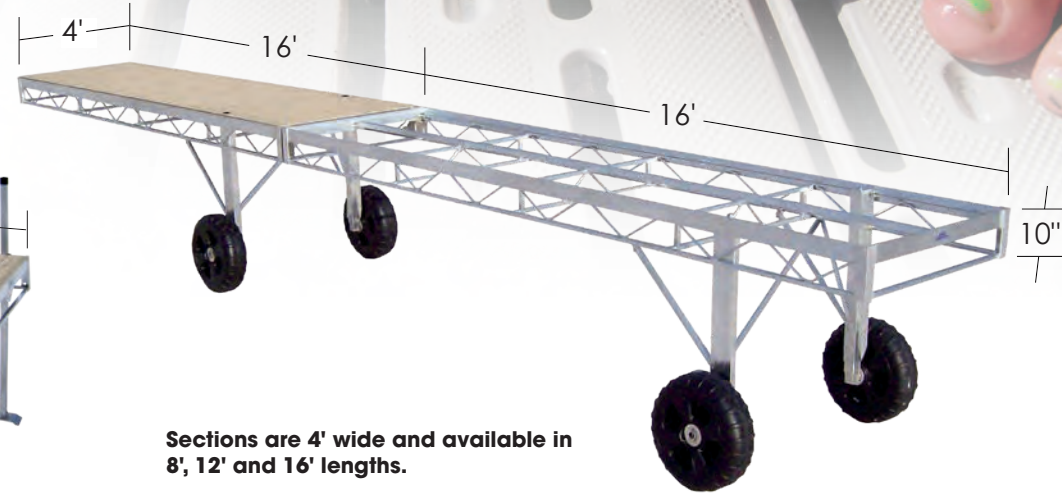

Sections are 4' wide and available in 8', 12' and 16' lengths.

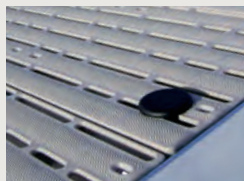
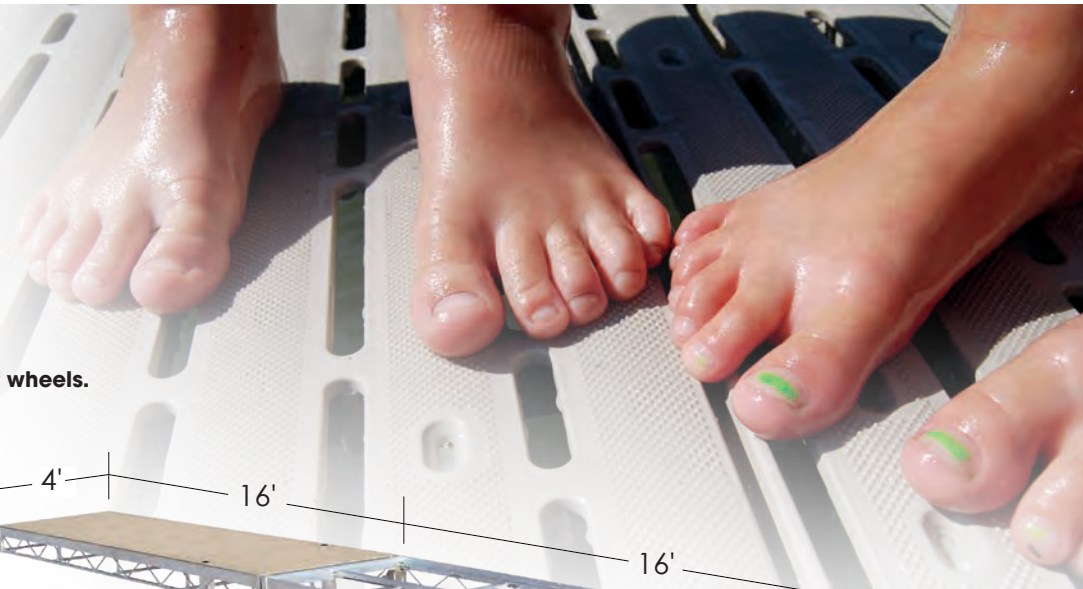

Telescoping legs

Are attached to an inner rail and adjust from the dock surface making leveling your dock easy. Durable rotomolded wheels provide many years of maintenance-free use.

DEPTH*	DOCK LEG
24" - 42"	SHALLOW DOCK LEG
36" - 60"	MEDIUM DOCK LEG
46" - 74"	DEEP DOCK LEG

* Measure from bottom of lake to water surface. Add 18" for overall height.

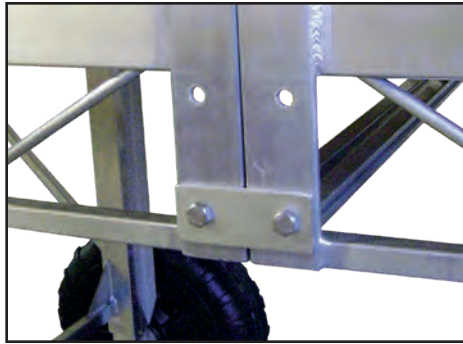

Standard Bolt System



Roll-In Dock Connections

Three connection options...Choose what's right for you!

Pier Pleasure roll-in dock sections can be connected using any of the three connection systems:

- Our **Standard Bolt System** allows you to connect your dock sections using non-corrosive bolts and nuts.
- The **Single-Stage Hook System** allows you to connect sections into any desired layout without tools and provides ease of installation and removal of your dock one 8' or 16' section at a time.
- The **Dual-Stage Hook System** gives you the ability to maneuver over uneven shorelines and remove multiple sections at the same time.

Both Hook Systems let you quickly add or remove sections without using fasteners. Disconnected sections can be moved independently to make installation and removal easy.

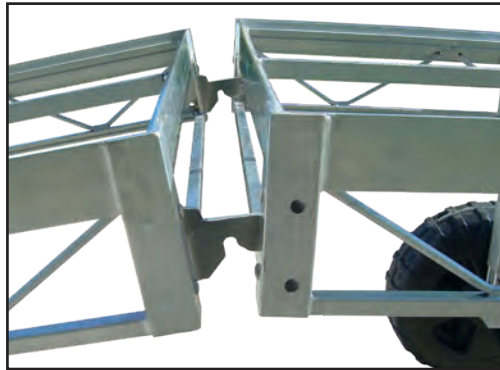

Dual-Stage Hook System

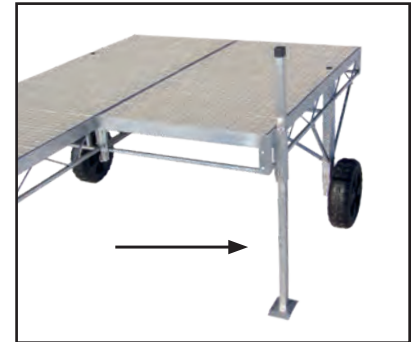
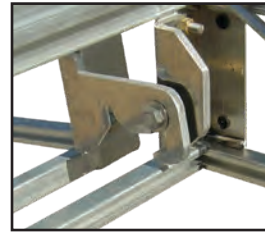

Set-Screw Post

Add additional stability by adding a set-screw post in any location.

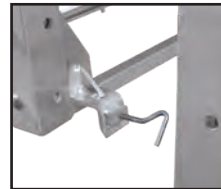
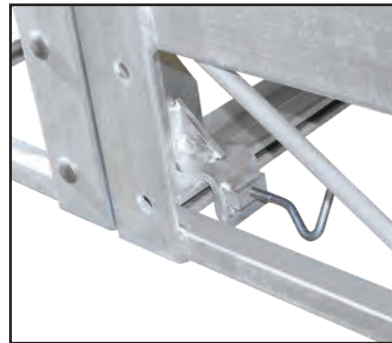

Single-Stage Hook System

Stainless Steel L-Bolt



Dock Accessories on pages 8-11 will also attach to Roll-In Dock.

See www.pierpleasure.com for new and additional dock accessories.



Wedge Section

Configure unique dock layouts with the use of a wedge section. The wedge section will allow sections to angle in different directions. Simple connection brackets are included to attach to any location on either side of the roll-in dock frame.



Dock Ramp

The perfect approach to your dock, as well as the most cost effective way to add length. The shore-end ramp attaches using the Pier Pleasure hinge system. It pivots up and down and easily detaches for seasonal storage. Available in 4', 8' and 12' lengths.



Roll-In Bench

Enjoy the day while resting on your Pier Pleasure bench. The aluminum frame with slanted backrest and plank seating provide a comfortable place to relax and enjoy your dock. Backrest and seating available in cedar and tan vinyl.



Corner Section

Increase your deck space by adding a 4' Corner Section. It provides a great spot to attach a bench or ladder.



Shore-End Dock Hitch

Use your ATV, garden tractor, or any vehicle with a ball hitch to maneuver your Roll-In dock system. 2" Ball.
(NOTE: Dual-Stage Hook System may be needed.)

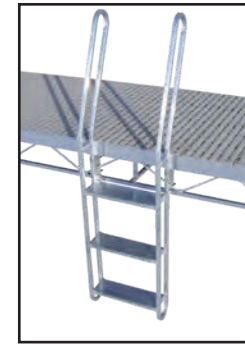

Ladder

The all-aluminum ladder extends high above the dock for enhanced leverage when climbing out of the water. Available with 3 or 4 steps.



Corner Bumper

Soft dock corner bumpers rivet to the dock frame and protect your watercraft from the corner of the dock.



Vertical Bumper

Protect your boat. The vertical bumpers are sturdy, hold the boat away from the dock and are easy to tie to. Available in a 4' length.



Shore End Wheel Kit

Shore End Wheel Kit eliminates lifting when installing and removing the roll-in dock. Wheel Kit fits all Pier Pleasure's post heights to accommodate your shoreline depth.



e-Dock

exceptional • engineered • economical

The Pier Pleasure e-Dock features an all aluminum dock frame and Titan deck panels. The features found in this post-style dock will meet and exceed the requirements that you are searching for in an economical dock. The simple design of any post-style dock keeps the cost very competitive compared to other dock designs. The Pier Pleasure e-Dock has additional features not found in other post-style docks.

- The tracks on the e-Dock frame rails allow for the aluminum channel connection brackets and post legs to be bolted in any location on the dock frame. This allows you to create any dock layout you desire. The dock layout can easily be modified in the future as your dock needs change.
- Every section has the option of 6' or 8' posts.
- Stainless Steel & Brass Fasteners – Rust free operation.
- Double-Braced legs add additional stability to every section.
- Clean dock appearance can be achieved by cutting off posts below the deck panels and still have height adjustment.
- The Titan deck panels may be secured permanently to the dock frame with stainless steel tek screws.

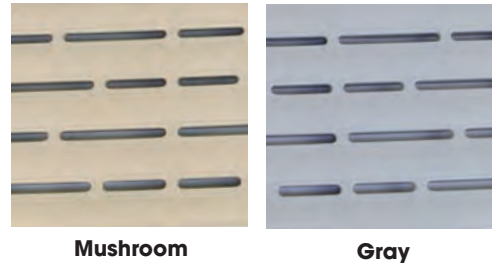

Titan Vinyl Deck Panels

Titan Deck was engineered so your dock will be the last thing on your mind. We know you would rather be having fun with your dock than working on your dock.

Titan Deck is made out of polypropylene, a sturdy plastic, that will take everything you and Mother Nature can throw at it. It comes standard with aluminum stiffeners for extra reinforcement.

All Titan Deck products come with UV protection which will prevent significant fading. Titan Deck will also handle any wild weather changes and is backed with a 12 year limited warranty.

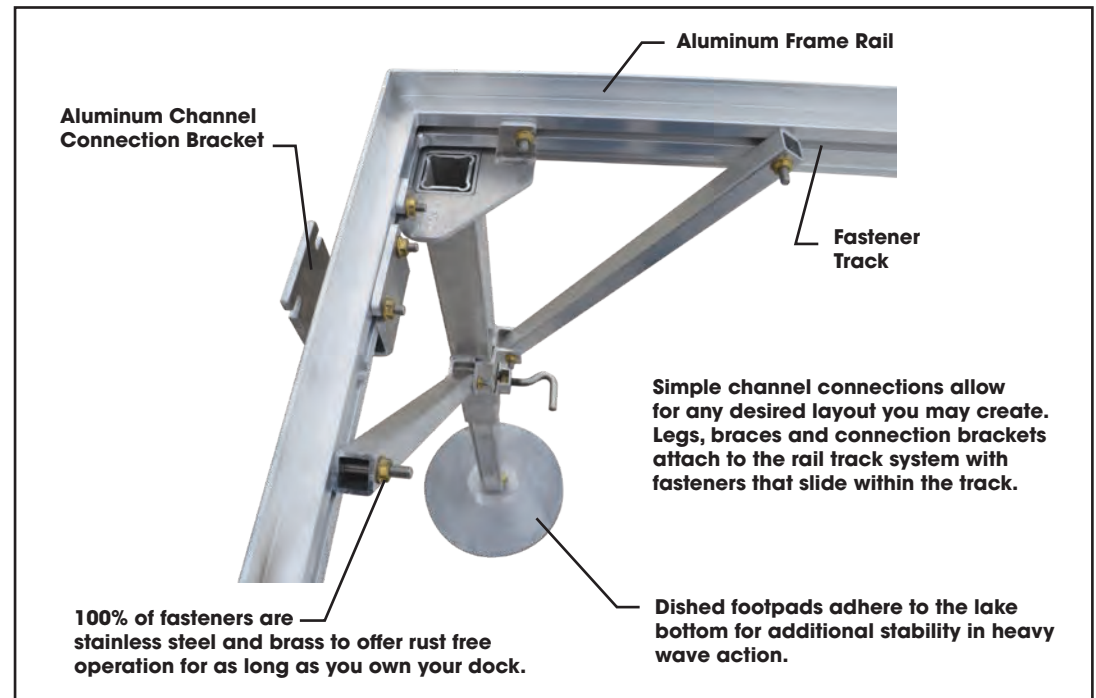



Post Legs

Post legs can pass through the deck or choose to cut them off below the deck for a clean appearance. Optional caps are available to cover notched panels.

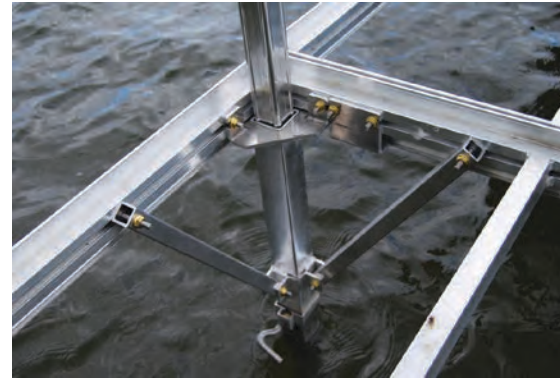
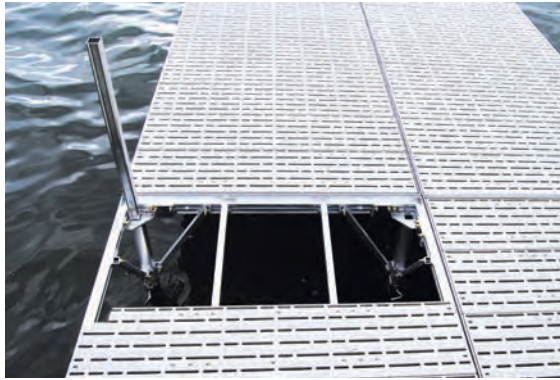

Double Braced

All legs are double braced for strength and stability on every section.



L-Bolt

Braced post legs are easily adjusted with a stainless steel set screw L-bolt that requires no tools.



Adjustable Height

Legs may be cut below the deck to create a clean appearance while still giving you 16" of adjustment.



Dock Ramp

Aluminum channel connections allow each e-Dock frame to ramp up or down. Maximum 8" height change per 8' length.



Wheel Kit (Optional)

Add wheels to the posts of any section to make installation and removal a simple task.



Dock accessories on pages 8-11 will also attach to e-Dock.



Lasting Relations...



Exceeding Expectations

Pier Pleasure strives to exceed expectations. Listening to customers and continually improving products based on that input is a priority at Pier Pleasure. Extra effort is given to remove sharp edges, corners and other defects. This ensures safety, maintains quality standards and ensures your satisfaction. Pier Pleasure's standards for excellence demand high-quality components, such as non-corrosive stainless steel bolts and pins, stainless cables, aluminum sheaves, brass nuts and aluminum construction.

Satisfied customers are a result of quality products and service. Quality products are produced by a skilled work force using top-line equipment. The experienced, committed work force at Pier Pleasure takes pride in the products they manufacture. Their ideas, opinions and recommendations have been an integral part in the development of Pier Pleasure and its products.



Quality and Value

All Pier Pleasure vertical lift models are standard with non-corrosive stainless steel bolts, stainless cables and brass nuts, giving you many years of service while maintaining a clean appearance. Aluminum sheaves are used to maximize cable life and to ensure lasting performance under heavy use. Pier Pleasure vertical lifts offer rigid diagonal V-bracing on both sides, giving uncompromised strength on demand when your boat is raised to maximum height. Our V-braced design also allows for non-restricted access to your boat from either side of the lift, which is ideal for slip installations.

Vertical lifts are excellent in shallow water conditions and when the weight of the boat exceeds 4000 pounds. In these applications, cantilever lifts lose their mechanical lifting advantage. Pier Pleasure vertical lifts are ideal for applications where the water level changes drastically and where maximum wave clearance is needed. Our direct vertical rise of 66" allows you to keep your boat high and dry without continually moving and adjusting your lift.



Model AL40120V-BB/AL50120V-BB

Lift shown with Full-Length V-Bunk.

Lift shown with Hemlock Tweed SeaMark™ fabric canopy.

Model AL30108V/AL30120V

Lift shown with Full-Length V-Bunk and optional Motorstop.



Stainless Pins with Grease Zerks



Aluminum Sheaves & Stainless Steel Cables



Pivoting Footpad Adjusts to Lake Bottom

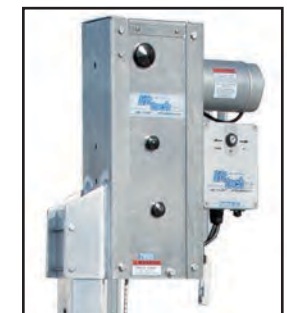

6000 lb. & 7000 lb. Lift Tech Winch – 110 volt or 24 volt

Model AL40120VP/AL50120VP

Lift shown with Pontoon V-Racks.

Designed 3 feet longer than other pontoon lifts to provide additional lifting support of your investment. Additional lift length increases lift stability in unfavorable weather conditions.

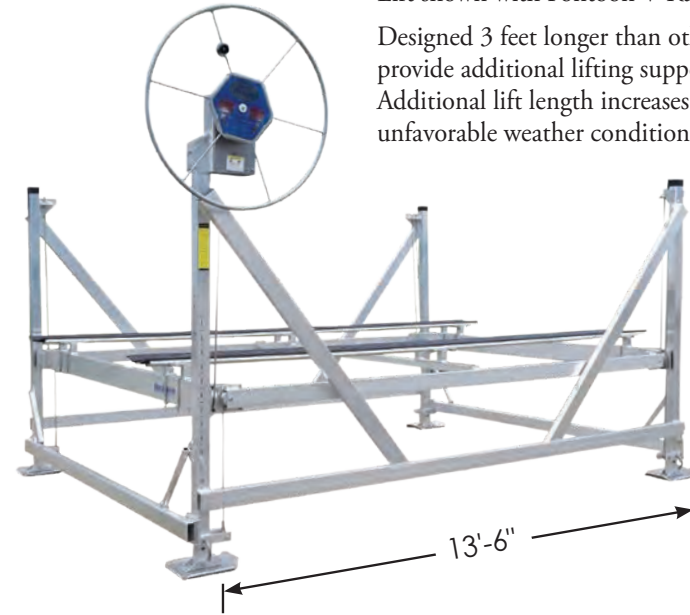

Model AL60120V-BB/AL70120V

Model AL60120V-BB shown with Full-Length V-Bunk.
Lift is available with 2-button pendant or remote fobs.
110 volt or 24 volt.



Model AL100132V-HYD

10,000# Vertical Hydraulic Lift

Model AL100132V-HYD shown with Full-Length V-Bunk.
See page 25 for more Vertical Hydraulic Lift details.

VERTICAL LIFT SPECIFICATIONS

	LIFT CAPACITY	BEAM WIDTH	LIFT LENGTH	LIFT WEIGHT
AL30108V	3000 lbs.	108"	108"	417 lbs.
AL30120V	3000 lbs.	120"	108"	432 lbs.
AL40120V-BB	4000 lbs.	120"	120"	506 lbs.
AL50120V-BB	5000 lbs.	120"	120"	514 lbs.
AL60120V-BB	6000 lbs.	120"	120"	532 lbs.
AL70120V	7000 lbs.	120"	120"	568 lbs.
AL80120V-HYD	8000 lbs.	120"	148"	792 lbs.
AL80132V-HYD	8000 lbs.	132"	148"	840 lbs.
AL100132V-HYD	10000 lbs.	132"	148"	990 lbs.

VERTICAL PONTOON LIFT SPECIFICATIONS

AL40120VP	4000 lbs.	120"	148"	547 lbs.
AL50120VP	5000 lbs.	120"	148"	560 lbs.
AL60120VP	6000 lbs.	120"	148"	581 lbs.



Vertical Hydraulic Boat Lifts

Available from 3,000 to 10,000 pound capacity.



Quick & Quiet Operation

Press a button on your wireless remote control. Seconds later your boat is in the water and ready to go. With a reliable, rugged and extremely easy to operate Pier Pleasure Hydraulic Boat Lift, you'll never hesitate to use your boat again.

The hydraulic cylinder is enclosed in a beam assembly. This allows for easy installation on any Pier Pleasure vertical boat lift. There is no direct exposure of the cylinder to water and no exposed moving hydraulic cylinder parts. This will provide a clean appearance and safe operation of the lift. Stainless bolts, pins and brass nuts are used on all lifts and accessories to prevent corrosion and maintain a clean appearance for many years. Remote fobs operate the hydraulic system along with the control box that can be mounted on the lift upright.



The hydraulic pump, motor and battery are enclosed in a poly box that can be locked. During the storage months, the hydraulic hoses can be disconnected and the box can be stored indoors. The lift is lighter to move during installation and removal because the hydraulic power unit is not attached to the lift.

An optional solar panel is available for charging the 12 volt battery. *(Battery not included with the system.)*

Solar Charge Regulator

The Solar Charge Regulator intelligently monitors the battery condition up to 100%, unlike standard regulators at 55-60%. This feature results in a full charge and conditioning of the battery. This solar charge regulator works on both 12-volt or 24-volt solar battery systems. The rugged aluminum housing and epoxy encapsulated electronics make this unit durable and waterproof. A Battery Status Indicator is the perfect solution to keep your batteries from being over-charged. Over-charged batteries can explode if the water evaporates inside of them.



Protect Your Investment

Pier Pleasure PWC boat lifts are built with the same quality components as our larger boat lifts. Pier Pleasure uses stainless bolts, cables and pins. There is no wood or carpet to deteriorate. Pier Pleasure's full-length v-bunk is standard with aluminum channel and extruded vinyl, making these lifts high quality and low-maintenance.

CANTILEVER



Stainless steel pin with grease zerk and stainless cable.



Adjustable vinyl V-Bunk with aluminum C-Channel with curved end.

VERTICAL



Stainless steel cables and UHMW guides.



Stainless steel pins with grease zerks.



Model AL1258 (Cantilever Lift)

Lift shown with standard Full-Length V-Bunk.

Model AL1564V-HLDC (Vertical Lift with Power Unit)

Lift is shown with standard Full-Length V-Bunk. Lift also has optional DC Power Unit, solar panel, and battery tray. Solar Charge Regulator is recommended with the solar panel.

AC Power Unit is also available as Model AL1564V-HLAC.



Model AL1564V-HL (Vertical Lift)

Lift shown with standard Full-Length V-Bunk.

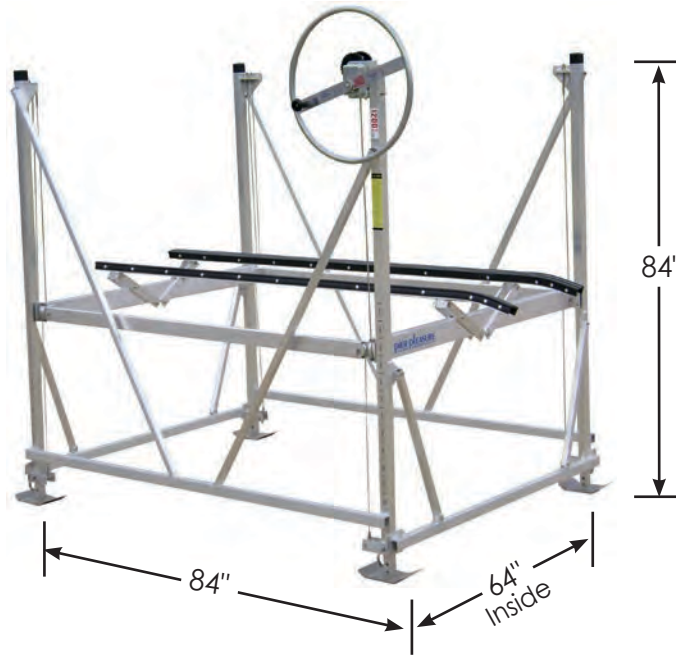

Not your average “Mini” Lift.

- Adjustable legs in all four corners allows the lift to be placed in deeper water along the dock.
- 7 foot lifting height for superior wave clearance and flexibility for water fluctuation.
- Aluminum and Vinyl V-Bunk assembly provides years of maintenance-free performance.



Full-Length Walkway

Filling fuel or installing the watercraft cover is made easier with the full-length walkway. Can be installed on both sides. Titan vinyl planks with aluminum frame for strength. Can be installed on all 1500# vertical lifts.



Full-Length Guide-On Stop

Makes loading the watercraft easy every time. Guide and stop adjust easily to your watercraft. Can be installed on all 1200# vertical lifts.

PERSONAL WATERCRAFT LIFT SPECIFICATIONS

	LIFT CAPACITY	BEAM WIDTH	LIFT LENGTH	LIFT WEIGHT
AL1258	1200 lbs.	58"	64"	112 lbs.
AL1564V-HL	1500 lbs.	64"	84"	149 lbs.
AL1564V-HLDC	1500 lbs.	64"	84"	162 lbs.
AL1564V-HLAC	1500 lbs.	64"	84"	162 lbs.

Keeping Your Investment Covered

Pier Pleasure offers a strong, all-welded frame with a sliding end that adjusts for easier tarp installation and removal. The tarp is secured in place by a continuous elastic shock cord and s-hooks, which make for simple installation and removal.

There are three choices of canopy tarps available. Pier Pleasure offers SeaMark™ Marine Fabric, a beautiful, colorfast Sunbrella® fabric that is waterproofed by combining the fabric with a textured marine grade vinyl backing. SeaMark™ has been a favorite of Pier Pleasure customers due to its beautiful appearance and durability. Hydrofend fabric is another choice offered by Pier Pleasure. Hydrofend is lightweight, reasonably priced and a durable material that stands up to elements at the lake. Also, Pier Pleasure offers a high-grade 18-ounce vinyl.

Pier Pleasure's canopy frame shape, unique sliding end and choices in canopy tarp materials combine to provide you with excellent boat protection that will look beautiful on your shoreline.

Also available is our freestanding canopy frame that allows you to use Pier Pleasure's canopies over track systems and pontoons with underdeck lifting kits.



Sliding Canopy Ends

Sliding ends on both ends of the canopy frame adjust for easier installation and removal. The canopy tarp will always fit perfectly every time.



Optional Canopy Braces

Canopy Braces recommended to support the front of the canopy frame on boat lifts with 26-ft and longer canopies. The recommendation for canopy braces with longer pontoon lifts is 28-ft canopy frames and longer.

SeaMark™ Fabric Tarp Colors



HEMLOCK
TWEED

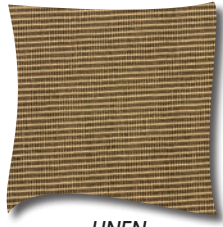

LINEN
TWEED



DUBONNET
TWEED



CADET
GRAY



BLACK

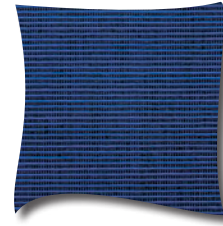

ROYAL BLUE
TWEED



CHARCOAL
TWEED



**Remember,
if it has to be waterproof,
it has to be SeaMark™**

For over 30 years, Seamark has been Pier Pleasure's most popular option due to the performance and integrity of the material over time. Defend against extreme precipitation and moisture with SeaMark fabric, the most waterproof fabric on the market. Engineered with durable Sunbrella fabric and 100% impervious waterproof back, SeaMark delivers strong on performance without sacrificing style. Superior weather resistance also makes SeaMark a top choice in shade material in environments that see extreme weather, delivering ultimate protection against heavy rain, harsh sun rays, mold, mildew, and other outdoor elements.

Hydrofend™ Fabric Tarp Colors



GREEN



TAN



MAROON



GRAY



BLACK



NAVY



Hydrofend's 8oz. fabric gives you up to six times better water resistance than uncoated fabrics. The marine fabric is engineered for superior breathability. To ensure lasting color and durability, Hydrofend is made from solution-dyed polyester. The coating on the underside prevents abrasion while the matte, woven top gives an attractive, outward-facing look. Hydrofend boat fabric is armed with a high double rub count as well as excellent tear and break strength. Lightweight and powerful, the protective fabric resists cold crack, mold, and mildew.

Additional Drop Canopy Tarps

- Canopy Skirt Extensions
- Mesh End Windows

Pier Pleasure offers several upgrades from the standard canopy tarp to customize for your boat coverage needs. The additional depth with taller height allows easy access for boats with towers and pontoon bimini tops.

12 or 24 inches of additional drop may be added to the standard canopy tarp's 9" valance. The 12" additional drop has a pocket sewn on the bottom for adding PVC piping for wind resistance weight.

The 24" additional tarps include a rear zippered end with buckles. Skirt Extensions provide a secure canopy tarp system that will not blow in the wind and will keep your boat fully covered. The extra deep framework offers greater protection for your boat or pontoon while allowing easy entrance and exiting from the boat lift.



Additional drop canopy tarps will provide superior protection for your boat from the sun, wind, rain and other damaging elements. The unique mesh end window design may be added to allow air to flow through the canopy.



Skirt extensions are used with 24" additional drop and allow the tarp skirt to be secured and prevent the tarp from blowing in the wind. The skirt extensions are adjustable from 29" to 45" to fit many different canopy sizes.

Freestanding Canopies

A freestanding canopy frame will allow you to use Pier Pleasure's canopies over pontoons with underdeck lifting legs, track systems and boats moored in a slip.

Pier Pleasure has two options for the freestanding canopies to choose from. The Freestanding Canopy Arms use augers, galvanized pipes and adjustable aluminum arms to secure the canopy to the lake bottom or ground.

The Freestanding Canopy Base Frame is an all-aluminum design that allows for easy installation and removal. The base frame design includes augers and galvanized pipe to anchor the canopy to the lake bottom and adjustable canopy height arms.



The **Freestanding Canopy Arms** are available with four or six adjustable arms. Optional bumpers or Full-Length Guides may be added to the arms for additional pontoon protection.



The **Freestanding Canopy Base Frame** is fourteen feet long. Adjustable drop legs are an optional add-on. Flared Full-Length Guides may be added for stress-free entering every time.





Canopy Frame - Raising End REC System

Easy Push Button Operation

Pier Pleasure's innovative Canopy Frame - Raising End (REC System) offers a simple and convenient add-on to the extended drop canopy tarps. The secured extension below the canopy frame combined with the REC System provides abundant protection for your investment, eliminating the need for zippers and buckles which allows the ease of opening and closing with push-button control.



Boats with towers and pontoons with bimini tops will benefit from the canopy end opening to allow easy entrance and exiting from the boat lift. The REC System's canopy tarp has unique mesh end windows on both ends for air flow along with both 12-volt or 110-volt power options.

Full cycle process from completely closed to fully open is 21 seconds. This quick opening and closing operation will allow you to get out on the water quicker and provide effortless operation throughout the day.





See www.pierpleasure.com for new and additional lift accessories.

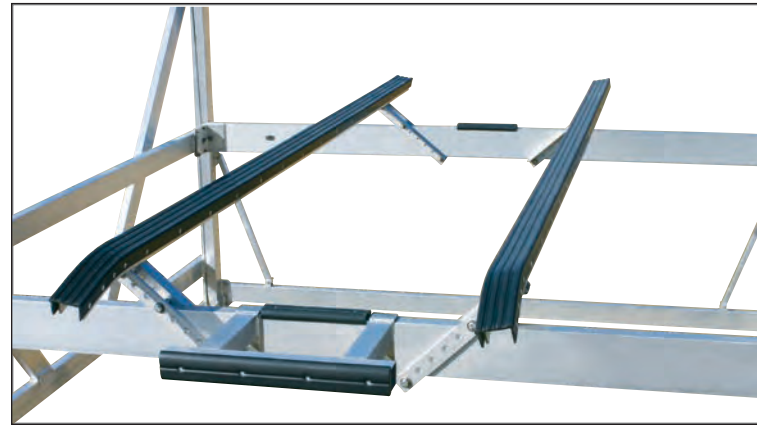

Full-Length Vinyl V-Bunk & Motorstop

The V-Bunk features an aluminum channel and extruded vinyl. The aluminum brackets and channel allow you to make simple adjustments and conform the V-Bunk to any boat hull shape. Pier Pleasure's standard mounting brackets have the necessary clearance needed for the in-board shaft on ski boats. The end of Pier Pleasure's V-Bunk is curved to reduce wear points and protect the hull of your boat.

With a motorstop installed on your boat lift, you can safely position your boat with ease. Extruded vinyl is installed to protect the lower unit of your motor.



Full-Length Vinyl Guide-Ons

These guide-ons are made from aluminum channel and covered with extruded vinyl. Flared ends allow for easier entrance into the boat lift. They are adjustable both vertically and horizontally.

Pier Pleasure Original Design Innovations Built into Every Pontoon Lift

- Longer and wider lift frame design provides more stable support when lifting the pontoon.
- Double V-Sides allow for easier boarding and exiting of passengers from either side.
- Thick, Aluminum Sheaves and Stainless Pins with Grease Zerks for superior lift performance.
- Stainless Cables provide durable and sustainable benefits.
- Stainless Bolts and Brass Nuts to prevent corrosion and stress-free adjustments.
- Custom Extruded Vinyl on all lift accessories for long-term performance.
- Flared Pontoon Guide-Ons for better guidance when entering and exiting the lift.



Vinyl Pontoon Bunks

Vinyl Pontoon Bunks are constructed with aluminum and vinyl extrusions. All lift accessories are constructed with aluminum rivets and stainless hardware to give many years of maintenance-free use. Vinyl Pontoon Bunks cradle the standard two tube pontoons and tri-toon pontoons.

Flared Pontoon Guide-Ons

Aluminum channel is formed and covered with a custom vinyl extrusion. Pier Pleasure's flared guide-ons extend beyond the rear of the lift. This will help keep the pontoon straight as you drive into the lift.



Tri-toon Adjustable Height Pontoon Bunks

- All three pontoon tubes may not be the same size. The Adjustable Height Pontoon Bunks allow the perfect fit and support every time.
- A single adjustable pontoon bunk is used when the middle pontoon tube is smaller than the outside tubes.
- The outside pontoon bunks are adjustable when the outside pontoon tubes are smaller than the middle tube.

Pontoon Centering Rack

Transform any standard lift into a pontoon lift with the heavy-duty Pontoon Centering Rack. The brackets and hardware allow the rack to be adjusted to your desired height. The rack lifts under the deck and guides the pontoon as it is driven onto the lift. The 2" x 10" wood boards are not included.



Pontoon Rails

Set up 3,000# - 6,000# standard boat lifts with Pontoon Rails. The formed aluminum rails are covered with maintenance-free vinyl extrusion. The rails both guide the pontoon into the lift and support it from the upper-deck. Add a motor stop or front stop for easy positioning of the pontoon on the lift.



Centering Guides

Centering Guides provide a simple way of positioning your boat and prevent damage to the boat's exterior. Available as a pair of Single Centering Guides or a pair of Double Centering Guides. Easy installation and adjustments make Centering Guides a good choice to protect your investment.

Vertical Lift with Double Centering Guides



See www.pierpleasure.com for new and additional lift accessories.



Lift Jack

The lift jack is a great helping hand when making adjustments to the lift legs or when installing wheels for installation and removal of your boat lift. The lift jack is 6 feet tall.



Wheel Kits

Using wheels when installing and removing a boat lift will make the job easier in most situations. Bracket kits are available to install on any additional lifts and use the same wheels. The plastic wheels may be left on after installation or removed if shallow water conditions require. Lift legs must be lowered into position after installation. The wheels are not intended to provide support while the boat is on the lift.



Diagonal Step

The aluminum step attaches to the side diagonal tube on the Pier Pleasure vertical boat lift. The skid resistant pad can be adjusted on the diagonal tube to the proper height and location to assist with stepping up into your boat.



Bunk Step

The aluminum bunk step with skid resistant pad will assist you as you climb from the dock into your boat. Attaches to the side bunk beam of a Pier Pleasure vertical boat lift. Adjustable to the height that you desire.



Battery Tray

Pier Pleasure offers several options for battery trays. Battery trays are available for 12-volt and 24-volt systems and can be installed inside the canopy frame or to the lift side diagonal. Visit Pier Pleasure's website for more electric power unit options.



Bow Stop

The bow stop will assist you in positioning your ski boat into the proper location on the lift. The bow stop is adjustable to accommodate the many designs and styles of boats.

LIMITED WARRANTIES

LIFTS	TERM
Aluminum Lift Frame Structure	20 Years
Lift Frame Weld Integrity	20 Years
Canopy Frame	5 Years
Seamark Fabric Tarp (Pro-Rated)	5 Years
Hydrofend Tarp (Pro-Rated)	5 Years
Aluminum Box Winch	5 Years
Pulleys And Winch	2 Years
Stainless Cables	2 Years
Hydraulic System: Cylinder - Pump - Hoses	2 Years
Lift Accessories	2 Years

DOCKS

Aluminum Dock Frame Structure	20 Years
Dock Frame Weld Integrity	20 Years
Leg Adjustment Mechanism	Lifetime
Extruded Vinyl Surfaces	20 Years
Titan Vinyl Surface (Pro-Rated)	12 Years
Aluminum Surfaces	5 Years
Wood Surfaces	90 Days
Dock Accessories	2 Years

A copy of Pier Pleasure's warranty is available upon request.



Talk to an Authorized Pier Pleasure Sales Representative about what Pier Pleasure can do for you.

NOTICE: All visual representations, dimensions, and specifications contained in this literature are based on the latest product information available at time of publication approval. The right is reserved to make changes in materials, equipment, design, specifications, models, and to discontinue models.

Dock layouts and photos shown in this literature may not meet local and state regulations in your area.

Pier Pleasure's warranty does not cover wind, storm, or ice damage. Do not leave any Pier Pleasure product in the water during winter months. Leaving product in freezing water in all situations is not recommended and voids all warranties.

GUARANTEE: If you are not satisfied with your purchase within 30 days from delivery, we will replace the product with another of equal value or refund your money.

PIER PLEASURE has been manufacturing a full line of quality marine products since 1974.

This product is constructed under one or more of the following patents. 4126006, 3468143, 3383822, 4125610, 3499541, 3562780, 4120057, 3361731



Quality is never an accident.
It represents the wise choice of many alternatives.



1270 N. River Dr. • Mankato, MN 56002
Phone (507) 625-2546 • 1-800-658-7010 • FAX (507) 388-6348
info@pierpleasure.com • www.pierpleasure.com

PLEASE CALL FOR THE DEALER NEAREST YOU.